



## **REQUEST FOR QUOTATION: GOODS & RELATED SERVICES**

**PROCUREMENT OF THE MINISTRY OF COMMUNICATION  
(2AP) 3P GENERATOR 100KV**

---

### **TABLE OF CONTENTS:**

<b>PART 1:</b>	<b>INSTRUCTIONS TO BIDDERS</b>
<b>PART 2:</b>	<b>LETTER OF AWARD</b>
<b>PART3:</b>	<b>REQUEST FOR QUOTATION</b>
<b>PART 4:</b>	<b>GENERAL CONDITIONS OF CONTRACT</b>
<b>PART 5:</b>	<b>SPECIAL CONDITION OF CONTRACT</b>
<b>PART 6:</b>	<b>SPECIFICATIONS OF ITEMS OR DESCRIPTIONS OF GOODS &amp; RELATED SERVICES</b>



## PART 1: Instructions to Bidders

### 1.Scope

- (a) The Purchaser is the Government of the Independent State of Samoa, represented by **Ministry of Communications and Information Technology** (“Principal”)
- (b) This Request for Quotation applies to the purchase of GOODS & RELATED SERVICES of a minor, simple nature.

### 2.Bidder Eligibility - The Bidder must:

- (a) be a bona fide business known by the Principal to be suitably qualified, experienced and financially resourced;
- (b) provide an authenticated copy of its currently valid Business License
- (c) if applicable, provide an authenticated copy of its VAGST Certificate from the Ministry of revenue Samoa
- (d) if applicable provide a notarized power of attorney authorizing the signatory of the Quotation to represent the Bidder, sign the Quotation and accept a Purchase Order

Notwithstanding that, requirements (b), (c) & (d) may be waived if previously submitted documents are valid for the specified delivery period

The Principal reserves all rights to reject any or all quotations submitted and re-advertise/retender the Goods & Related Services.

### 3.Bidder Qualification – The Bidder must provide:

- (a) Description of items or services of a similar nature & value that are the subject matter of this RFQ, that the Bidder has satisfactorily delivered within the last two (2) years – these items or services must have an annual average value of **SAT\$25,000.00** or more;
- (b) Summary of all items & services currently contracted or in progress;
- (c) A bank statement in the name of the bidder for the immediately past three (3) months;
- (d) References & contract details of at least three (3) past and present clients who can attest to good character and reliability;
- (e) A work plan or delivery program detailing the provision of item and services from its production to its completion.

### 4.Responding to the Request for Quotation

- (a) In responding:
  - (i) The Bidder shall verify and take care to comprehend the description and specification of all items.
  - (ii) The Bidder shall enter unit prices, extended prices and total price on the Request for Quotation form.
  - (iii) The Bidder shall verify its agreement with stated provisions for quotation validity, delivery period, warranty period, manufacturer’s authorization & performance security. All variations from stated conditions shall be explained in a covering letter.
  - (iv) The Bidder is responsible for providing a complete and correct quotation. An incomplete quotation may be grounds to reject any quotation submitted.

### 5.Quotation Price :

- (a) All prices shall be quoted in Samoan Tala (SAT)
- (b) Prices shall be fixed for the duration of the specified period for delivery
- (c) Unless otherwise stated, the quotation shall be for the full quantity stated on the Request for Quotation
- (d) Quoted prices for goods supplied from within Samoa shall be quoted ex-works (EXW) plus local delivery charges to named place of delivery
- (e) Quoted prices for goods supplied from abroad shall include all insurances, duties and freight, sales taxes & other taxes, plus local delivery charges to named place of delivery, with delivery terms CIP.

### 6.Bid Security

- (a) A Bid Securing Declaration Form must be signed and submitted.
- (b) The Bid shall be valid for the period identified in the Request for Quotation.
- (c) A Bidder who, without good cause, withdraws during the period of quotation validity, or does not accept corrections of errors, or fails to accept the Letter of Award if offered or fails to produce the Performance Security (if required) will be excluded from participating in Request for Quotation process for one year.

## 7. Quotation Submission

- (a) Bidders shall submit only one (1) quotation for items & services meeting the same description or specification.
- (b) Quotations should be submitted to the procuring entity address stated on the Request for Quotation, no later than the specified time & date and in pursuant to section C.5.1 (a) or (b) of the Procurement Operating Manual 2020.
- (a) Bidders **may not/shall not** submit their quotation electronically, via the Government of Samoa e-Tendering Portal ([https://portal.tenderlink.com/mof\\_samoa/](https://portal.tenderlink.com/mof_samoa/)), details of which are provided in ANNEX I
- (c) Late quotation will not be considered and shall be returned to the Bidder unopened.

## 8. Quotation Opening

- (a) The opening of quotations will be undertaken by officers of the Principal and in the presence of representatives from the Ministry of Finance, Attorney General's Office and Ministry of Works, Transport & Infrastructure.
- (b) The opening of the quotation shall be
  - (i) Carried out fifteen (15) minutes after closing; and
  - (ii) Opened to interested members of the public to attend.
- (c) The results of the quotation evaluation shall be available on request, after the Contract Award, denoting only the successful Bidder.

## 9. Quotation Evaluation & Contract Award

- (a) Quotations shall be evaluated to establish substantial responsiveness to eligibility & qualification requirements, specified technical schedules, commercial conditions and this ITB.
- (b) The bidder found to be substantially responsive after the evaluation shall be, subject to (c) below, awarded the contract. That Bidder then becomes the Successful Bidder.
- (c) After arithmetical checking and correction, the quotation of the Bidder(s) found to be substantially responsive shall be evaluated for lowest price, which shall be the basis of award
- (d) Award notification shall be effected by the Principal issuing the Letter of Award (see Part 2) to the Successful Bidder.

- (e) Once the letter of Award is signed by both parties the:
  - i. Request for Quotation at Part 3; and
  - ii. The General and Special Conditions at Part 4 and Part 5 respectively; and
  - iii. Specification of Items or Descriptions of Goods & Related Services at Part 6;

Shall be the terms and conditions which will govern the delivery of the item & Services. The Principal shall be termed the 'Purchaser' and the successful bidder shall be termed the 'Supplier'.

- (f) Notwithstanding the above, the Principal reserves the right to accept or reject any quotations, or to cancel the quotation process at any time prior to the award.
- (g) The unsuccessful Bidder may, within ten (10) days of the announcement of the award, request reasons why it/they were not successful, but cannot request reasons why other Bidders were not successful.

## 10. Performance Security

- (a) If a Performance Security is required, the Purchaser shall issue a Letter of Award which shall serve as notification of award of contract.
- (b) The Successful Bidder shall provide a Performance Security within seven (7) days after the issuance of the Letter of Award, in the amount specified in the Request for Quotation.

## 11. Insurance

- (a) The basis of the agreement between the Purchaser and the Supplier will be delivery and acceptance at the named place for delivery. The Supplier will bear all risks for transportation between point of dispatch and point of delivery
- (b) Accordingly the Supplier shall arrange appropriate insurance cover

## 12. Packaging & Delivery

- (a) The Supplier shall ensure that all goods are appropriately packaged to avoid physical damage, breakage or corrosion
- (b) Delivery shall be made to the specified place of delivery within the specified delivery period

**13. Payment:** The Purchaser shall make payment to the Bidder within thirty (30) days of delivery of goods and completion of related services

**14. Inspection of Goods/Products**

The Purchaser may request to view the items of Goods/Products during the evaluation of the Bidders bid to deliver goods or goods related services.

**15. Warranty**

The Bidder must provide a warranty for all goods/item to be provided, for the period set out in RfQ (see Part 3).

**16. Corrupt & Fraudulent Practices**

The Purchaser requires that Bidders observe the highest standards of ethics during the procurement and execution of Government of Samoa contracts, to the extent that corrupt, fraudulent, collusive and coercive practices and conflict of interest occurring in quotation, delivery & completion processes may result in disqualification, termination of purchase order and penal sanctions.

**Office use only:**

<b>Eligibility/ Qualifications Compliance</b>			
No.	Complies? tick	No.	Complies? tick
2a		3a	
2b		3b	
2c		3c	
2d		3d	
		3e	

## **Annex I to Part 1: Instruction to Bidders**

### **Procedure for Electronic Submission of Quotations**

1. The quotation shall be electronically submitted via the Government of Samoa's e-Tendering Portal only. The Bidder shall use this, and only this, link to submit its electronic quotation.
2. The Portal shall automatically expire on the submission deadline, specified in the relevant Invitation to Bid. No extension shall be provided after the expiry date of the tender.
3. At the submission deadline, and not before, Tender Link will forward to the Portal's Administrator access to the tender box electronic keys to open proposals.
4. To ensure the integrity and compliance with Part 1 (Instructions to Bidders), the Opening of the Tender Box can only be actioned by the Ministry of Finance's designated Administrator. For security purposes, all openings are dated and time stamped, ensuring compliance of their opening with Clause 9 of this Instructions to Bidders.

**PART 2: LETTER OF AWARD**

insert Principal's letterhead

insert date

insert the address of the Supplier

**LETTER OF AWARD: PROCUREMENT OF 3P STANDBY GENERATOR FOR MINISTRY OF COMMUNICATION AND INFORMATION TECHNOLOGY\_ 2AP**

**RfQ:** . MCIT-2024-002

1. The Government of Samoa (the 'Purchaser') issued the above request for quotation on insert date for the above Goods and/or related services. The deadline for the request for quotation closed on insert date. Your company (the 'Supplier'), as insert description of the Supplier submitted a quotation on insert date. The evaluation of the said quotation took place on insert date.
2. We wish to inform that your quotation has been successful. The Principal is desirous for you, the Supplier, to perform deliver the goods and/or the goods related services in accordance with the:
  - (a) The Request for Quotation, RfQ Ref No. insert Ref No. (the 'RfQ') inclusive of Instructions to Bidders;
  - (b) General Conditions of Contract attached to the RfQ;
  - (c) Special Conditions of Contract attached to the RfQ;
  - (d) Specification of items or Description of goods & related services.
3. The Principal, acting by and through the Chief Executive Officer (if applicable)/Honourable Minister of the insert procuring entity now signs this letter to confirm that it accepts the RfQ by the Supplier. Please sign and date the space indicated as confirmation of your acceptance to carry out the work in accordance with documents canvassed in paragraph 2 of this letter.

**SIGNED AND EXECUTED** by the )  
 Insert CEO/Honourable Minister of )  
 procuring Entity ) .....  
 In the presence of: )

.....  
(Witness)

.....  
(Name & Designation)

**AFFIXED HERETO** is the **COMMON** )  
**SEAL**of insert name of Contractor ) .....  
 (Director)

In the presence of:  
 .....  
 (Director/Secretary)

## PART3: REQUEST FOR QUOTATION



### GOVERNMENT OF THE INDEPENDENT STATE OF SAMOA

**Purchaser Name:** MINISTRY OF COMMUNICATION AND INFORMATION TECHNOLOGY  
**Address:** FLOOT 6, TTATE BLDG  
**Contact Details:** 26117

### REQUEST FOR QUOTATION: Minor Goods/ Related Services

<b>RFQ NAME.</b>	PROCUREMENT OF 3P GENERATOR (100KVA) STANDBY MINISTRY OF COMMUNICATIONAND INFORMATION TECHNOLOGY - 2AP	<b>RFQ No.</b>	MCIT - 2024-002.
<b>TO</b>	<b>SUPPLIER NAME</b>	enter registered trading name	
	<b>CONTACT PERSON</b>	enter name of sales representative/ manager; mobile phone & landline no.	
	<b>OFFICE ADDRESS</b>	enter street/ road name and township name	

Please provide your quotation for the following **GOODS & RELATED SERVICES** by 9<sup>th</sup> September 2024 at the following address Ministry of Finance, Level 4, Central Bank Building

Quotation Validity	90 days		<b>RFQ APPROVAL</b>	<b>TY11B APPROVAL</b>	
Required Delivery Period	120 days				
Required Delivery Date	AT LEAST 90 DAYS FROM CONTRACT SIGNING				
Delivery to	BUILDING 2AP - MULINUU		<i>Initial</i>	<i>initial/ date</i>	
Delivery Terms	EXW	CIP	Lefaoalii Unutoa Auelua -Fonoti )		
Required Warranty Period	days 547		Chief Executive Officer (MCIT)		
Manufacturers Authorization	is not required		<i>Date</i>		
Performance Security	XXPercent total quoted price		Bank Draft or Bank Guarantee		
<b>No.</b>	<b>Description</b>	<b>Qty</b>	<b>Unit</b>	<b>Unit Price</b>	<b>Extended Price</b>
1.	Generator Set	1			
2.	Installation	1			
3.	Transport & Lift & Carpenter	1			
4.	Testing	1			
5.					
6.					
ATTACH SHEET FOR ADDITIONAL ITEMS			<b>TOTAL</b>		
We certify that we comply with eligibility & National Ownership requirements of Instructions to Suppliers clauses 2a to 2c.(overleaf). If our offer is accepted, we undertake (a) to deliver goods					



& services in accordance with our offer above, (b) to provide the Performance Security in the prescribed form, amount & time (c) to abide by this quotation for the Validity Period stated above.		<b>Supplier's Authorized Officer</b> <i>Sign, Stamp where applicable</i>
COUNTRY (S) OF ORIGIN		<b>Date</b>
<b>IF AVAILABLE, PLEASE ATTACH MANUFACTURER'S BROCHURE &amp; SPECIFICATION SHEETS</b>		

# Bid-Securing Declaration

*The bidder shall fill in this Form in accordance with the instructions indicated utilizing the bidder's official letterhead.*

Date: *date (as day, month and year)*

RFQ No.: *MCIT – 2024 - 002*

To: *(Chief Executive Officer, Ministry of Works Transport and Infrastructure)*

We, the undersigned, declare that:

We understand that, according to your conditions, bids must be supported by a Bid-Securing Declaration.

We accept that we will automatically be suspended from being eligible for bidding in any contract with the procuring entity for the period of time of *number of months or years* starting on *date*, if we are in breach of our obligation(s) under the bid conditions, because we:

- (a) have materially modified or withdrawn our bid during the period of bid validity specified in the Request for Quotation Form; or
- (b) do not accept a correction of errors;
- (c) having been notified of the acceptance of our bid by the procuring entity during the period of bid validity, (i) fail or refuse to execute the Contract; or (ii) fail or refuse to furnish the Performance Security, if required, in accordance with the ITB.

We understand if the Bid Securing Declaration becomes forfeit we will be disqualified from participating in any Government procurement for one year regardless of the source of funding. We understand this Bid Securing Declaration shall expire if we are not the successful bidder, upon the earlier of (i) our receipt of your notification to us advising the execution of the contract with the successful bidder; or (ii) twenty-eight (28) days after the expiration of our bid.

Signed: *signature of person whose name and capacity are shown in the capacity of legal capacity of person signing the Bid Securing Declaration*

Name: *complete name of person signing the Bid Securing Declaration*

Duly authorized to sign the bid for and on behalf of: *complete name of bidder*

Dated on \_\_\_\_\_ day of \_\_\_\_\_, \_\_\_\_\_ date of signing  
Corporate Seal (where appropriate)

**Note:** *In case of a Joint Venture, the Bid Securing Declaration must be in the name of all partners to the Joint Venture that submits the bid*

## **PART 4: GENERAL CONDITIONS OF CONTRACT: MINOR GOODS & RELATED SERVICES**

- 1 APPLICATION CONTEXT: These Conditions apply only for use within the Independent State of Samoa for contracts awarded through request for Quotation processes for procurement of Goods and Goods related services within section C.2.2.6 of the Procurement Operating Manual 2020.
- 2 NAMES OF PARTIES: As stated in the Letter of Award (see Part 2) above, the Government of Samoa as represented by the Ministry of Communication and Information Technology is the 'Purchaser' and the successful Bidder is the 'Supplier'.
- 3 CONTRACT DOCUMENTS: Subject to the order of precedence set forth in clause 4 of these GCC, all documents forming the Contract (and all of its parts) are intended to be correlative, complementary, and mutually explanatory. The Contract Agreement shall be read as a whole.
- 4 ENTIRE AGREEMENT: The Contract constitutes the entire Agreement between the Purchaser and the Supplier and includes the following documents which replaces all communications, negotiations and agreements (whether written or oral):
  - a. Letter of Award
  - b. The Request for Quotation, RfQ Ref No. MCIT – 2024-002. (the 'RfQ') inclusive of Instructions to Suppliers;
  - c. These General Conditions of Contract;
  - d. Special Conditions of Contract;
  - e. Specifications of Items or Description of Goods & Related Services.
- 5 CONTRACT PERIOD: This Contract shall commence on the date specified in the SCC and shall be for a period as identified in the SCC (the 'Completion Period') and shall be completed by the Completion Date identified in the SCC.
- 6 CONTRACT PRICE: The Employer shall ONLY pay to the Supplier the Contract Price set out in the SCC. The Supplier shall provide Purchaser with a Claims for Payment which shall:
  - a. State the amount of the contract price received to date each head of costs;
  - b. The amount of the Claim for Payment including the Head of Cost under which it is claimed;

- c. Detail the Goods supplied and the Services performed and completed since the previous claim for Payments;
- d. Report on the progress of the Supply and Services.

The Principal's Representative shall issue a Progress Payment Certificate once he/she is satisfied that the Claim for Payment is bona fide. The Employer must pay the amount in the Claims for Payment fourteen (14) days from when he/she is satisfied with the Claim for Payments.

The Principal shall retain a certain percentage, set out in the SCC, of the total quoted price until the completion of the Defects Liability Period.

- 7 PRINCIPAL'S REPRESENTATIVE: The Principal's Representative shall be an Employee of the Principal responsible for liaising with the Supplier and general administration and supervision of the Services. The Principal's Representative is set out in the SCC.
- 8 AMENDMENT: No amendment or other variation of the Contract shall be valid unless it is in writing, is dated, expressly refers to this Contract and is signed by a duly authorized representative of each of the Parties to the Contract.
- 9 LANGUAGE: The applicable language of the Contract is English.
- 10 LAW: The applicable law of the Contract is the law of the Independent State of Samoa.
- 11 INTERPRETATION: If the context requires it, singular means plural and vice versa. The reference to one gender shall mean the other gender. All monetary references shall be to Samoan Tala unless otherwise stated.
- 12 COMMUNICATIONS/NOTICES: Communications between parties to the Contract shall be effective only when communicated or delivered in written form with proof of receipt, to the address specified in the SCC.
- 13 COPYRIGHT: Both parties shall observe requirements of the Samoa Copyright Act 1998 and international conventions concerning material produced by third parties.
- 14 DOCUMENT OWNERSHIP: Unless otherwise provided in Contract schedules and as applicable to Contract category, all plans, specifications, designs, reports, other documents and software prepared by the Supplier shall become and remain the property

- of the Employer, without encumbrances of ownership by other parties. The Employer shall establish proof of ownership of existing materials provided to the Supplier for contract performance and the Supplier shall establish the right to use and reproduce any materials produced by third parties to be used in contract performance.
- 15 CONFIDENTIALITY: The Parties shall keep confidential and shall not divulge to any third party any documents, data or other information furnished directly or indirectly in regard to the Contract, without written consent of the other Party.
- 16 CONFLICT OF INTEREST: The Supplier shall not have a conflict of interest. The Supplier warrants that to the best of its knowledge and after making diligent inquiry, at the date of signing the contract, does not have a conflict with the interests of the Employer or is likely to arise in the performance of the Works. If during the performance of the Service a conflict of interest arises or appears likely to arise, the Supplier agrees to:
- (a) Immediately notify the Employer in writing;
  - (b) make full disclosure of all relevant information relating to the conflict; and
  - (c) Take such steps as the Employer may reasonable require to resolve or otherwise deal with the conflict.
- 17 CURRENCY OF PAYMENT: The currency for payment shall be in Samoan Tala.
- 18 PRICE ADJUSTMENT: Price adjustment for changes in economic conditions shall not apply to any contract resulting from RFQ processes.
- 19 TAXES AND DUTIES: The Supplier is liable for all taxes and duties, in accordance with the particular application context and the laws of the Independent State of Samoa.
- 20 ACCOUNTING, INSPECTION & AUDIT: The Supplier shall permit and also require its sub-suppliers and consultants to permit, the Government and/or its authorized appointees to inspect the Supplier's office and all accounts and records relating to contract performance and/or tender submission and to have such accounts and records audited by the Government's appointed auditors. Moreover, acts by the Supplier to materially impede inspections and audits are a prohibited practice subject to termination and declaration of ineligibility.
- 21 LIMITATION OF LIABILITY: Except for its negligence or misconduct in performing the Contract and its related obligation to pay liquidated damages, the Supplier will not be liable to the Principal for any form of consequential loss or damage, loss of use, loss of production or loss of profits plus interest cost. The total liability of the Supplier under the Contract or civil law shall not exceed one hundred and fifty percent (150%) of the Contract Price, except that this shall not apply to costs of rectifying defective equipment, works or other deliverables.
- 22 SUSPENSION: The Employer may, with written notice of the nature of default, suspend all payments to the Supplier if the Supplier fails to perform particular requirements of the Contract and shall require the Supplier to remedy the default within thirty (30) days of Supplier receiving the suspension notice.
- 23 TERMINATION: Where a party defaults on any of its obligations under this Contract, the other party may give notice requiring that the failure be remedied within fourteen (14) days and if not remedied within that time, may terminate the Contract immediately.
- The Principal may terminate the contract if any of the events set out in the SCC occurs.
- Notwithstanding this, the Purchaser may terminate the Contract for convenience. If the Contract is terminated, the Supplier shall stop the Services immediately, make the Site safe and secure, and leave the Site as soon as reasonably possible. If the Contract is terminated for the Purchaser's convenience or because of a fundamental breach of Contract, the Purchaser's Representative shall prepare a statement of amounts owing to the Supplier based on the Services done and Goods delivered as final payment.
- 24 FORCE MAJEURE: If, because of the result of an event of Force Majeure causing delay and the Supplier is unable to perform its Contract obligations, it shall not be liable for its Performance Security forfeiture, liquidated damages or termination for default. The Supplier shall notify the Principal in writing of such condition, its cause and the nature of the delay or its inability to perform its Contract obligations as soon as practicable.
- 25 LIQUIDATED DAMAGES: Unless the Completion Date is extended in accordance with clause 8, the Supplier shall pay damages to the Principal at a rate per day stated in the SCC for each day that the Completion Date is later than

- the intended Completion Date. The total amount of liquidated damages shall not exceed the amount defined in the SCC. Payments under this provision shall not affect the Suppliers Liability. The Principal may deduct liquidated damages from payments due to the Supplier.
- 26 GOOD FAITH: The Parties undertake to act in good faith with respect to each other's rights under this Contract and to adopt all reasonable measures to ensure the realization of the contract's objectives, operate fairly together without detriment to each other and exercise their best efforts to agree on actions which may be needed to remove causes of unfairness.
- Provided that failure of such action shall not be the subject of formal legal redress indicated in Clause 27 following.
- 27 AMICABLE SETTLEMENT: Either Party with an unresolved issue concerning actions or inaction of the other Party may seek resolution through an independent third party empowered to enable resolution.
- 28 DISPUTE SETTLEMENT: Any dispute arising out of the Contract which cannot be settled amicably according to Clause 27 shall be settled in accordance with the provisions of the Arbitration Act 1976 of Samoa and best international practice.
- 29 INDEMNITY: The Supplier shall, subject to Clause 21, at all times indemnify, hold harmless and defend the Purchaser, its officers, employees and agents from and against any loss or liability reasonably incurred or suffered by any of those indemnified arising from any claim, suit, demand action or proceeding by any person against any of those indemnified where such loss or liability was caused by any willful, unlawful or negligent act or omission of the Supplier, its employees, agents or Sub-Suppliers in connection with the Contract.
- 30 PASSING OF PROPERTY: Property in, and risk of loss of or damage to the Product shall pass to the Supplier upon delivery of the Produce to the headquarters of the Purchaser, with its address set out at the SCC, Apia, Sāmoa. The Purchaser shall, upon delivery, provide the Supplier with an acknowledgement in writing of receipt of the Products/Goods, thereby passing the property in, and risk of loss or damage to, the Product/Goods to the Purchaser.
- 31 COMPLIANCE WITH POLICIES AND PROCEDURES: The Supplier must, when using the Purchaser's Premises or facilities, comply with all reasonable directions of the Purchaser and all procedures and policies of the Purchaser including those relating to occupational health (including no smoking), safety and security in effect at those premises or in regard to those facilities, as notified by the Principal or as might reasonably be inferred from the use to which the Premises or facilities are being put.
- 32 INSPECTION, REJECTION AND ACCEPTANCE: GOOD/PRODUCTS:
- (a) The Purchaser or its Representative may, prior to the supply of the Goods/Products by the Supplier to the Principal and with reasonable notice to the Supplier, inspect any and all products that are to be supplied by the Supplier.
  - (b) The Purchaser or its Representative may reject any or all products to be supplied by the Supplier if found not to be in accordance with the Contract.
  - (c) The Purchaser shall not be liable to pay for rejection or inspection of the Products/Goods or its associated materials or equipment.
- 33 INSPECTION, REJECTION AND ACCEPTANCE: GOOD/PRODUCTS: GOODS RELATED SERVICE
- (a) The Supplier shall be deemed to have satisfied itself before tendering as to the correctness and sufficiency of the tender of the Service and the Contract Price and acknowledges that it has inspected the Premises and its conditions before it agreed to supply the Services.
  - (b) The Purchaser can inspect the progress of the Services and the Supplier will grant the Principal or its representative access to the Premises where the Services are being performed. If there is defect or the Principal is dissatisfied with the services, it may by written notice require the Supplier make good any defects arising from good workmanship at no cost to the Purchaser.
- 34 INSURANCE: The Supplier will be responsible for taking out any appropriate insurance coverage during the duration of the Contract.
- 35 ASSIGNMENT: The Supplier shall not assign this Contract or sub-contract any portion of it without the Principal's prior written consent.
- 36 WAIVER: If a party does not exercise (or delays in exercising) any of its rights, that failure or delay does not operate as a waiver of those

rights. A single or partial exercise by a party of any of its rights does not prevent the further exercise of any right. In this clause, "rights" means rights or remedies provided by this Contract or at law.

37 WARRANT ON GOODS/PRODUCTS: The warranty period for the Goods/Products, its associated materials and equipment shall be the period set out in the RfQ from delivery and its installation, whichever is sooner. If the Principal gives notice of any defect or omission discovered in any of the Goods/Products during the warranty period, the Supplier must correct that defect or omission without delay and at no cost to the Principal. The Supplier must meet all costs of, and incidental to, the discharge of its warranty obligations, including but not limited to any packing, freight, and disassembly and reassembly costs.

38 CLEANING UP: The Supplier shall, to the satisfaction of the Principal's Representative keep the Site and Services and/or Works tidy and clean during the execution of the Service and at its completion. The ownership of any leftover or surplus material at the Completion of the Works shall remain vested in the Principal.

---

**PART 5: SPECIAL CONDITIONS OF  
CONTRACT: MINOR GOODS &  
RELATED SERVICES**

GCC	Details
Clause 5	Commencement date: Date of Contract signing Completion Period: 90 days at least Completion Date: 90 days from contract signing at least
Clause 6	The Contract Price shall be an amount not exceeding SAT95K (incl. all taxes)
Clause 7	Principal's Representative shall be: I Lefaoalii Unutoa Auelua-Fonoti Chief Executive Officer TATTE Building Ministry of Communication and Information Technology
Clause 12	For communications to the: (a) Principal It must be delivered to the following address: Ministry of Communication and Information Technology Level 6, TATTE Building SOGI (b) Supplier It must be delivered to the following address: insert address
Clause 23	(a) The Supplier stops the work for fourteen (14) days when no stoppage of the work is shown on the current Program. (b) The Supplier is made bankrupt or goes into liquidation other than for a reconstruction or amalgamation. (c) The Supplier does not maintain a Security, which is required; (d) The Supplier has delayed the completion of the works by the number of days for which the maximum amount of liquidated damages can be paid i.e. 0.5% of the contract price per day. The total amount must not exceed 15% of the Contract Price)
Clause 25	Rate per day: 0.5% Maximum amount: 15% of the Contract Price





**PART 6: SPECIFICATION OF ITEMS OR DESCRIPTION OF GOODS RELATED SERVICES**

## **Technical Specifications**

**SCOPE OF WORK ;**

The scope of works involves the following tasks:

**I. Plans:**

Plans and schedules will be led by the Principal Technician/Engineer. The new genset will be installed by a contractor under the supervision and auspices of the CEO who is a qualified engineer, ACEO 2AP (output manager of the project) and the Technical/Engineering team.

**II. Project Date/Time:**

A kick off date and time to be confirmed when materials arrive. It is normally at least 3 months to order a genset. A Confirmation arrival date is dec'2024. It is required to follow project plans and schedules to minimise delay and time for the installation.

**III. Installation:**

All these installations must be carried out during the daily sunlight hours. Installation and commissioning of Genset must be done while doing roof carpentry work as well.

- Will create Plan how to pull off old genset from inside shelter
- Pushing in new genset using lift machine
- Install new generator according to design plans of 3-phase load.
- Check all cabling and sizes of current capacities allowable
- Check Load Current
- All Maintenance to be completed
- Must do Manual / Auto Testing
- Checklist and acceptance

**PROJECT STAGES:**

**- IMPACT**

- i. Technical Improvement will support and show no power failure of network service
- ii. Back Up Supply (Gen + Batteries) will back up the network and current load when EPC mains accidentally fail.
- iii. Continuation of better service offer and maintain better customer service in all areas
- iv. Maintaining strong business enforcement with all clients

**STATEMENT OF FACT**

Had a discussion with a generator servicing electrician on the 09<sup>th</sup> Apr, 2024 during the survey, we have specified the requirements /needs for the replacement of genset due to power insufficiently supply because of its old age.

Plans to look at for the safety of network load transmission and installation

- Plan A: daylight work to get these all done in minimal time

- Plan B :-Backup \_ portable generator
- Must have good weather/
- Pull Old gen out
- 2. Push New gen in
- Installation/Commissioning & build Front shelter same time

#### **RISKS AND MITIGATION**

- Generator may face lateness in its replacement work largely due to budget and shipping restraints
- Pandemic world problems will affect Time Frame and costs
- War problems causing high costs of fuel / oil causing delays of delivering in air/sea

#### **ISSUES**

Raining whether may cause delay

---

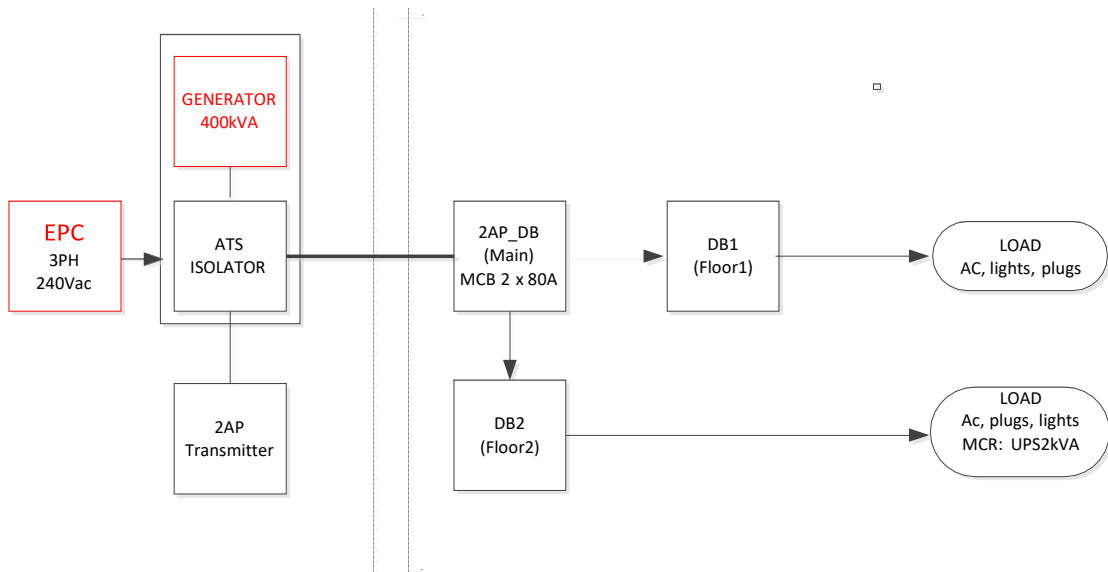

**Fig 1: Design – 2AP 3P 100 kVA Generator**



**Fig 2: Photos - 2AP 3P 100 kVA Generator**

